

ZANUSSI

抽濕機

使用手冊

CE



型號：ZD1919

使用本產品前，請先詳讀本手冊中的指示，
並將本手冊好好保留於適當地方以備未來參考用。

為了避免機身內部受損，使用前請至少要讓機身直立 2 小時以上。

ZANUSSI is a registered Trademark used under license from AB Electrolux (publ)

目錄

安全注意事項

警告事項.....	2
注意事項.....	2
電氣資訊.....	3

抽濕機上的控制面板

控制面板.....	4
其他功能.....	5

零件之辨識

零件之辨識.....	6
本機之安裝位置.....	7

本機之操作

當使用本機時.....	7
移除所收集的水.....	8

保養與維修

抽濕機的保養與清潔.....	9
----------------	---

疑難排解

疑難排解.....	10
產品參數表.....	11

詳細閱讀本手冊

於本手冊中你可以找到如何適當使用本機的提示。只要採取一些預防性維護工作就能節省你許多時間與金錢並延長本機的使用壽命。你也可在故障排除章節中找到許多常見問題的解答。若你先閱讀過疑難排解中的建議，你就可能不需要尋找客戶維修服務了。



注意事項

- 本裝置可於有適當人員監督下或給予如何安全使用本裝置的指示並讓其了解涉及的風險後由八歲以上的小孩，或運動，感官與感知能力受限，或缺乏相關知識或使用經驗的人來使用。孩童不得胡亂使用本裝置。本裝置的清潔與維護也不得由孩童在無人監督下進行。(EN 標準要求)
- 除非有適當人員監督下或給予如何安全使用本機的指示並讓其了解涉及的風險，本機並非設計給運動，感官與感知能力受限，或缺乏相關知識或使用經驗的人 (包括孩童) 來使用的。(IEC 標準要求)
- 本機旁有孩童時應有成人監督，確保他們不會胡亂使用本裝置。
- 若電源線受損時，必須由製造商，其維護代理商或合資格的技術人員來更換，以免發生危險。
- 本裝置的安裝應根據國家電線安裝的相關法例進行。
- 有電氣加熱器的家電必須與易燃物件相隔至少一公尺的距離。
- 本機需要修理或維護時須聯絡合資格的技術人員。



安全注意事項

為了避免對使用者或其他人與財物造成傷害，請務必遵循下述指示。
忽略這些指示的不當操作可能會導致人員傷害或財物受損。

安全嚴重性是以下列方式分類的。

 警告事項	這個符號表示有可能造成死亡或嚴重人身傷害。
 注意事項	這個符號表示有可能造成人身傷害或財物損失。

本手冊中使用的符號代表下列意義：

	切勿這麼做。
	確保要遵循指示。

 警告事項		
切勿超過電源插座或連接裝置的評定電能。	切勿藉由開關電源來啟動或停止本機。	切勿損失電源線或使用未經授權的電源線
●否則可能會因為產生過熱現象而觸電或引致火災。	●可能會因為產生過熱現象而觸電或引致火災。	●可能會觸電或引致火災。
切勿更改電源線的長度或與其他電器分享插座	切勿用濕手來將插頭插入或拔出插座	切勿將本機放得太靠近熱源
●可能會因為產生過熱現象而觸電或引致火災。	●可能觸電	●塑膠零件可能會融化而引致火災
切勿於本機發生奇怪聲響，氣味或煙霧時將電源切斷	切勿自己試圖將本機拆開或修理	清潔本機前，務必關掉電源並將電源線拔開。
●可能會引致火災或觸電	●可能導致機器故障或觸電	●可能觸電或人身傷害
切勿於如汽油，苯，稀釋劑等易燃物附近使用本機	切勿飲用或使用本機滲出的水	切勿於本機運行中將集水箱拿出來
●可能會爆炸或引致火災	●水中可能有污染物導致你生病	●可能本裝置的傷害且觸電

 注意事項		
切勿於狹窄空間中使用本機。	切勿將本機置於會給水濺到的地方。	務必將本機放置在水平且穩定的樓面
●缺乏通風可能會導致過熱與引致火災	●水可能會滲入本裝置導致絕緣給破壞。可能會觸電或引致火災。	●若本裝置翻覆，可能會導致水滲出而損傷財物，或觸電或引致火災。

 注意事項		
切勿用布或浴巾掩蓋住進氣或出氣口。	於有下列人員的房間內使用本機時要特別小心：	切勿於有在處理化學品的區域使用本機
●缺乏通風可能會過熱與引致火災	●嬰兒，孩童，長者與對濕度敏感的人	●本機可能因為化學品與溶液揮發在空氣中而導致裝置損傷
切勿將手指或其他異物插入本機的百葉窗或開口中。特別要注意警告孩童這個禁忌。	切勿將重物放在電源線上，並要注意切勿讓電源線受到擠壓	切勿爬上或坐在本機上
●可能觸電或機器故障	●可能引致火災或觸電的風險	●若你跌倒或本機翻覆，都可能造成你的人身傷害
務必緊緊插好濾網。每兩週清潔濾網一次。	若水滲入本機，立刻將本機關機並將電源線拉開後，就聯絡一位經驗證過的技術人員。	切勿將花瓶或其他水瓶放在本機上面
●在沒有濾網的情況下使用本機，可能導致機器故障。	●可能導致機器故障或意外	●水可能會滲入本機，導致絕緣給破壞，甚至造成觸電或火災。

電器資訊

- 製造商說明牌位於本機的後面板，上面記載了本機特定的電氣與其他技術資料。
- 確保本機有適當接地。適當接地是很重要的，可以將觸電與火災的風險降到最低。本機的電源線有三個分叉，其中一個是接地叉用來防護不受到觸電的風險。
- 本機必須插在有適當接地的牆壁插座上。若你要用的牆壁插座沒有適當接地，或由一個延時保險絲或電流斷電器保護的話，就必須請合格的電工來安裝適當的插座。
- 確保本機安裝後牆壁插座還是易於接近的。
- 切勿將本機連接到延長線或轉接插頭上。
- 為了避免人身傷害的可能性，務必於安裝與維護前先將本機的電源線拔出插座。

抽濕機的控制面板

注意：你購買機種的控制面板可能會與下列示意圖稍微不同。

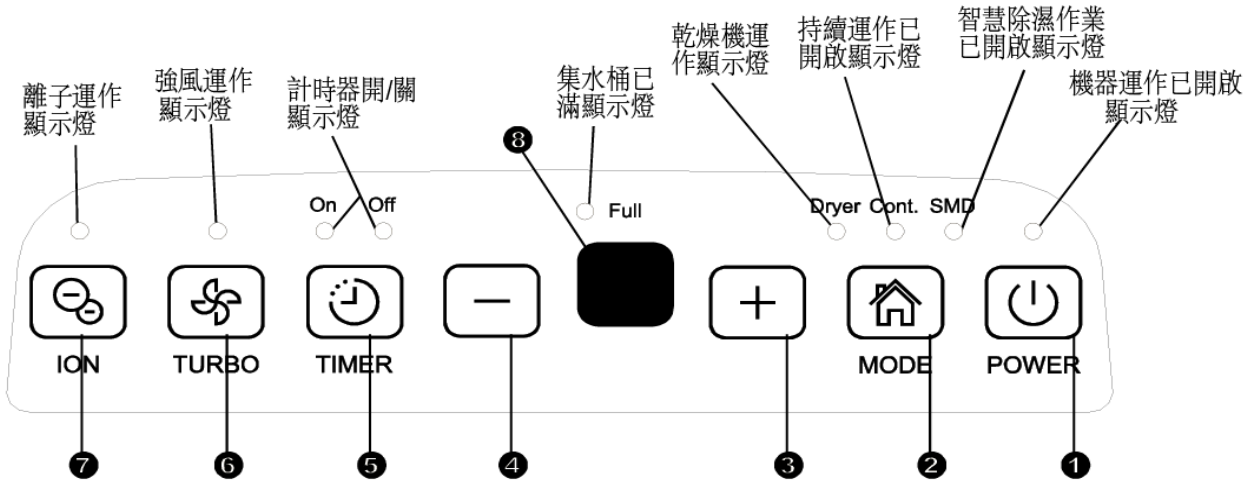

圖一

控制面板

當你按下按鈕來改變操作模式時，本機會發出一個嗶聲來顯示模式的改變。

1 電源面板

按下來打開或關上抽濕機。

附註：當壓縮機啟動或停止運作時會發出大聲響是正常的。

2 模式面板

按下來從下列模式中選擇想要的模式：抽濕，乾燥，持續抽濕，與智慧抽濕。

附註：乾燥與智慧抽濕模式為選項模式。

3/4 \oplus/\ominus ：下移/上移面板

●濕度設定控制板

濕度水準可設定在相對濕度 35%到 85%之間，以 5%為漸進間隔。

要有較乾燥的空氣，按下 \ominus 面板來設定一個較低的數值（%）。

要有較濕潤的空氣，按下 \oplus 面板來設定一個較高的數值（%）。

●計時器設定控制板

用上移/下移面板來將自動啟動與自動停止時間設定在 0.0 與 24 之間。

5 計時器面板

按下來啟動自動啟動與自動停止功能後用 \oplus 與 \ominus 鍵來設定數值。

6 加快面板

控制風扇速度。按下來選擇高速或正常風扇速度。要盡快除去濕氣時，就將風扇控制設定在高速。當濕氣已經減少且需要較安靜的運作時就將風扇控制設定為正常。

7 離子面板（選項）

按一下來啟動離子產生器。離子會於電離過程中自動產生，可消除空氣中的化學氣體與塵埃粒子。再按一次就可以停止該功能。

8 顯示

顯示所設定的相對濕度水準（在 35%與 85%之間）或自動啟動/自動停止時間（0 到 24），然後顯示實際的房間相對濕度（準確度為 5%，介於 30%與 90%之間）。

故障碼與保護碼：

AS – 濕度感測器故障。將本機電源拔掉後再插回插座。若持續出現本故障碼，請聯絡維修人員。

ES – 溫度感測器故障。將本機電源拔掉後再插回插座。若持續出現本故障碼，請聯絡維修人員。

其他功能

集水箱已滿位燈

當集水箱需要清空，或集水箱已被移除，或集水箱沒有放置在正確位置時會閃爍。

自動關機

當集水箱已滿，或集水箱已被移除，或集水箱沒有放置在正確位置時抽濕機會自動關機。當設定的濕度已達到時，本機也會自動關機。有些機種的風扇馬達會持續運作。

自動除霜

當蒸發器盤管起霜時，壓縮機會停機而風扇會持續運作直到霜消失為止。

附註：當啟動自動除霜時，本機可能會發出冷卻劑流動的聲音，這是正常現象。

等三分鐘後再重新開機

當本機停機後，是無法於三分鐘內重新開機的。這項功能是用來保護本機的。本機會於三分鐘後自動重新開機。

智慧抽濕（選項）

在智慧抽濕模式下，本機會自動根據室溫將房間濕度控制在很舒適的 45%到 55%的範圍內。此時無法啟動濕度設定功能。

P1 – 本機正在除霜。請給予本機足夠時間來除霜。本機自動除霜完畢後這個保護碼就會消失。

P2 – 集水箱已經裝滿，或集水箱沒有放到正確的位置。將集水箱清空並放回正確位置。

E3 – 本機出現故障。將本機電源拔掉後再插回插座。若持續出現本故障碼，請聯絡維修人員。

EC – 偵測到冷卻劑外洩。本機具備自我偵測的新科技，一旦顯示區出現 EC 時，表示本機偵測到冷卻劑外洩，請立即通知維修人員。

自動重新開機

若本機因電源中斷而意外停機，本機會於電源接上後自動重新開機並啟動先前的模式與設定。

設定計時器

● 當本機開機時，先按下計時器鈕，計時器關機顯示燈會亮，顯示自動停止功能已經啟動。再按一次計時器鈕，計時器開機顯示燈會亮，顯示自動開機功能已經啟動。

● 當本機關機時，先按下計時器鈕，計時器開機顯示燈會亮，顯示自動啟動功能已經啟動。再按一次計時器鈕，計時器關機顯示燈會亮，顯示自動停止功能已經啟動。

● 按下或持續按著 UP（上移）或 DOWN（下移）面板來將自動啟動的時間每次增減半個小時，直到十個小時後，就會每次增減一個小時到二十四個小時。控制面板會倒數到時間完畢時啟動自動功能。

● 被選定的時間會於五秒鐘內登錄入本機內，接著本機就會回復到顯示先前的濕度設定。

● 當已經設定自動開機與停止的時間時，在同一個程序中，計時器關機顯示燈會亮來確認自動開機與停止時間已經輸入本機程式中了。

● 隨時將本機開機或關機，或將時間設定為 0.0 都會取消自動開機/停止的功能。

● 當 LED 顯示視窗顯示出 P2 碼時，自動開機/停止的功能就會被取消。

零件之辨識

乾燥機模式 (選項)

本機可於乾燥機模式下會先讓抽濕功能達到最大，而風扇也會設定在高速。風扇速度接下來會根據實際房間濕度自動調整。本機會於十個小時的運轉後跳出乾燥機模式。

附註：

- 乾燥機模式只能在密閉房間內進行，切勿打開門窗。
- 要讓抽濕功能最為有效，請先將房內的濕布擰乾。
- 確保抽濕機氣流直接吹在濕布上，如圖 A 所示。
- 太厚重的濕布可能無法獲得最佳的乾燥效果。

⚠️注意事項

- 切勿讓布遮蓋住本機的出氣口。這樣可能會導致過熱，火災或機器故障。
- 切勿將濕布放在本機上面，且切勿讓水滴進本機中。這樣可能會導致觸電，漏電或機件故障。



圖 A

零件之辨識

前方

- 1 控制面板
- 2 抓把 (兩側都有)
- 3 排氣格子孔
- 4 集水箱
- 5 集水程度視窗

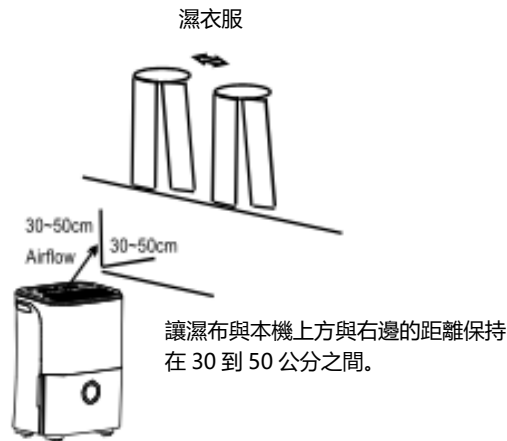
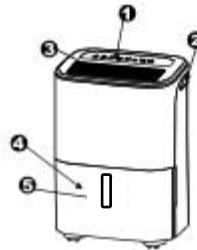

圖二

後方

- 1 排水管出口
- 2 輪腳
- 3 電源線與插頭
- 4 進氣格子窗
- 5 空氣濾網 (在格子窗後面)
- 6 電源線桶 (只有在要將本機儲藏起來時才使用)

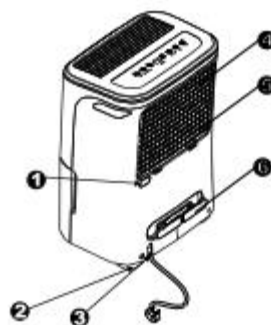

圖三

附註：所有本手冊內的圖片都是示意圖。你所購買機種的實際形狀可能會稍有不同，但其功能與操作都是相同的。

本機放置的位置

放在地下室的抽濕機只在有適當空氣流入流出空間的情況下才能有效地乾燥附近的封閉儲存區域。

- 切勿在室外使用裝置。
- 本抽濕機只適用於室內住宅的應用，不適用於商業或工業區的應用。
- 將本裝置放置在平滑，水平且能支撐本機與集水箱滿位時總重量的樓面。
- 本裝置周圍均須要有至少 20cm 的淨空空間來讓空氣流通。
- 室溫不得低於攝氏五度（華氏 41 度）。低於這個溫度，盤管就會結霜而影響抽濕效率。
- 將本裝置放置在遠離乾衣機，加熱器與暖爐的地方。
- 可將本裝置放在儲存書籍或有價值物品且想避免濕氣的地方。
- 可將本裝置放在地下室來預防濕氣造成的損害。
- 要將所有該房間的門窗與出氣口都加以關閉。

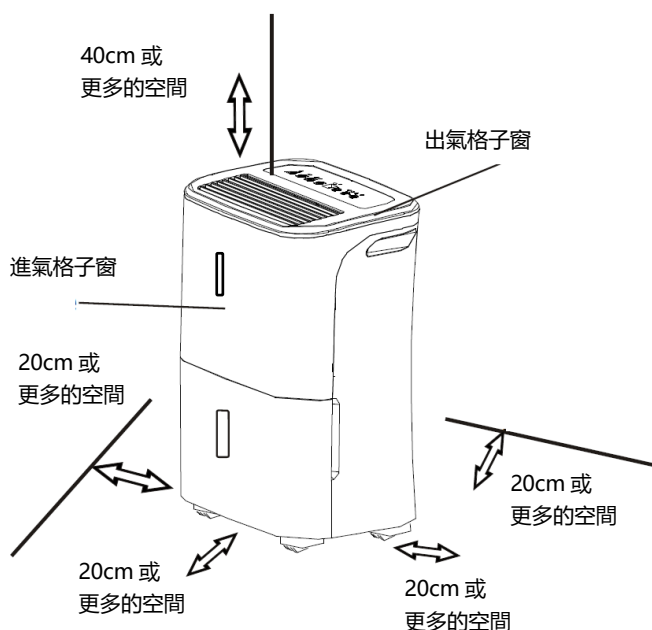

圖四

輪腳（本機底端的四個點）

- 輪腳能自由移動
- 切勿強推輪腳在地毯上移動，也切勿於集水箱中有水時移動本機。（本機可能會翻覆而讓水四濺。）

當使用本機時

- 第一次使用本抽濕機時，要讓本裝置持續運作二十四小時。
- 本裝置是設計於室溫介於攝氏 5 度/華氏 41 度與攝氏 35 度/華氏 95 度間的環境中運作的。
- 若本機已關機，但需要迅速再開機時，請等候至少三分鐘讓機件能正常運作後再重新開機。
- 切勿將本機插入有許多家電共用的插座中。
- 選擇適當的位置，確保人能輕鬆接觸到電源插座。
- 只將本裝置插入有接地的插座。
- 確保集水箱有放好，否則本裝置無法適當運作。

附註：當集水箱中水位達到特定水準時，請小心移動本裝置避免翻覆。

移除所收集的水

有兩種方式來移除所收集的水

1. 用集水箱

- 在本機關機時，若集水箱已滿，本機會發出嗶聲八次且滿水顯示燈會亮，數位顯示器會出現 P2 字樣。
- 在本機開機時，若集水箱已滿，壓縮機會關機，風扇會再運作三十秒來吹乾凝結器上的水分後關機，接下來本機會發出嗶聲八次且滿水顯示燈會亮，數位顯示器會出現 P2 字樣。
- 慢慢拉出集水箱。緊緊抓住兩側的抓把後將集水箱直直拉出，不要讓水濺出來。否則水桶可能會翻覆而讓水四濺。切勿將集水箱放在地面上，因為其底部不平。否則水桶可能會翻覆而讓水四濺。
- 將集水箱中的水倒出後將集水箱放回去。要確保集水箱放入定位且穩穩卡在本機內後本機才會適當運作。
- 當集水箱放回定位後本機會自動開機。

附註：

- 在移除集水箱時，切勿碰觸到本機內的零組件。這樣可能會導致本機受損。
- 確保集水箱有放回本機內的定位。讓集水箱撞擊本機內部或沒有將其放回定位都可能讓本機無法運作。
- 當移除集水箱時，若發現本機內部還有些水，務必加以擦乾。

2. 持續排水

- 透過將本機接上一條水管（沒有隨附，須另購）後便可自動將水排出到地板上的排水孔中。
- 將後面排水孔的蓋子切開後將排水管（管徑為 13.5 釐米）接上，然後用水管將水引領到地板上的排水孔或一個適當的排水裝置（參見圖七）。
 - 確保水管有接好，沒有滲漏現象。
 - 將水管拉到排水孔，並確保地面沒有突起導致水流不順。
 - 將水管另一端放入排水孔中，確保水流會平順進入排水孔中。切勿讓水管口朝上。
 - 選定想要的濕度與風扇速度設定後讓持續排水能啟動。

附註：不再使用持續排水功能時，將水管從本機的排水孔上移除。

1. 將集水桶先拉出來一點



圖五

2. 用同樣力度抓住集水桶兩側後，慢慢將其由本機中拉出來

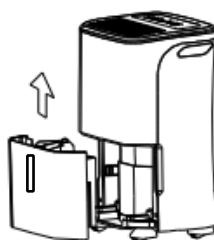

圖六

3. 將水倒出來

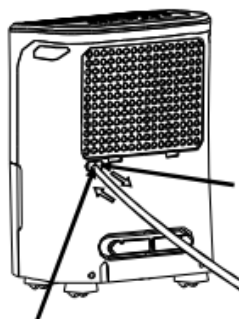

將蓋子打開

將水管連接上排水孔

圖七

本抽濕機的保養與清潔

將本抽濕機關機且將電源線從插座中拔出後才能開始清潔。

1. 清潔格子窗與外殼

- 用清水與柔和的清潔劑即可。切勿使用漂白劑或磨料。
- 切勿直接將水灑在主機上。這樣可能會導致觸電，讓本機的絕緣給破壞，或導致機體腐蝕。
- 進氣與出氣格子窗常會沾惹塵埃，可以用吸塵器或毛刷來清。



圖八



圖九

2. 清潔集水箱

每隔幾週就應把集水箱清潔一次，以預防黴菌與細菌累積滋生。將集水箱裝一部分水後加入一些柔和的清潔劑。讓水在集水箱中沖洗後倒掉，再用清水沖洗。

附註：切勿使用洗碗精來清洗集水箱。清潔後要將集水箱穩穩放入本機定位後本機才能運作。

3. 清潔空氣濾網

在前方格子窗後面的空氣濾網每三十天就應檢視並清潔一次，若有需要時可以更頻繁的清潔。

附註：切勿用水清洗或將濾網放進自動洗碗機清洗。



圖十

移除濾網時：

- 抓住濾網邊緣後往上拉，然後如圖八所示將濾網拉出來。
- 用溫的肥皂水清洗濾網。清洗後讓濾網晾乾之後才放回去。切勿將濾網放入洗碗機中清洗。

連接濾網時：

- 將濾網從下方向上插入本機中。參見圖十所示。

注意事項：

切勿在沒有濾網的情況下操作抽濕機，這樣會讓塵埃與纖維塞住本機而影響效能。

4. 當會有很長一段時間不使用本機時

- 在關機後，等待一整天的時間後才將集水箱中的水倒掉。
- 將本機，集水箱與濾網都清潔乾淨。
- 用塑膠袋將本機覆蓋好。
- 將本機垂直立放在一個乾燥且通風良好的地方。

疑難排解

在打電話給維修人員前，可以先看看這裡的建議。

問題	要檢查些什麼
無法開機	<ul style="list-style-type: none">● 確保抽濕機的插頭有完全且穩穩地插入插座中。● 檢查房屋的保險絲/斷電盒。● 抽濕機是否已經達到預設的濕度水準，或集水箱已滿。● 集水箱未放入定位。
抽濕機無法有效抽濕	<ul style="list-style-type: none">● 還沒有足夠時間來抽濕。● 確保沒有窗簾，百葉窗或傢俱堵住抽濕機的前面或背面。● 濕度控制沒有設定到夠低的數值。● 檢查所有的門窗與通氣口都已經關閉。● 室溫過低，低於攝氏五度（華氏 41 度）。● 房間內有煤油加熱器或其他會釋出水蒸氣的裝置。
本機在運作時發出大聲的噪音	<ul style="list-style-type: none">● 空氣濾網堵塞住了。● 本機有點傾斜而不是垂直立著。● 樓面不夠水平。
盤管出現結霜現象	<ul style="list-style-type: none">● 這是正常現象。本抽濕機具備自動除霜功能。
樓面出現水	<ul style="list-style-type: none">● 水管與排水接頭間鬆動，或水管連結鬆動了。● 試圖要用集水箱來收集水，但後面的排水接頭塞給移除了。
顯示器上出現 ES，P2 或 P2 字樣	<ul style="list-style-type: none">● 這些是故障碼與保護碼。參見有關抽濕機上控制面板的段落。

產品參數表

型號：	ZD1919
除濕能力：	9L/DAY (26.7°C RH=60%) 20L/DAY (32°C RH=90%)
額定電壓：	220V~
額定頻率：	50Hz
輸入功率	234W (26.7°C RH=60%) 280W (30°C RH=80%)
水箱容積：	3L
風量：	150 m ³ /h
製冷劑：	R134a/95g
噪音（聲壓級）：	47dB(A)
淨重：	15.1kg
排氣壓力：	1.7MPa
回氣壓力：	0.7MPa



有關氟化氣體

- 氟化溫室氣體往往藏在緊緊密封的家電設備中。至於（在有些機種中的）這些氟化溫室氣體的類型，數量與相當的二氧化碳噸數方面的資訊，請參見該機種的相關標籤。
- 本機的安裝，維護服務與修理必須由合資格的技術人員來執行。
- 本機的卸裝與回收必須由合資格的技術人員來執行。

本產品的設計與規格會因產品改良後在沒有事先通知下就隨之加以改變。細節請向銷售代理商或製造商諮詢。

CD031IU-DF(ZG)

16120100000251

ZANUSSI

DEHUMIDIFIER

USER MANUAL

CE

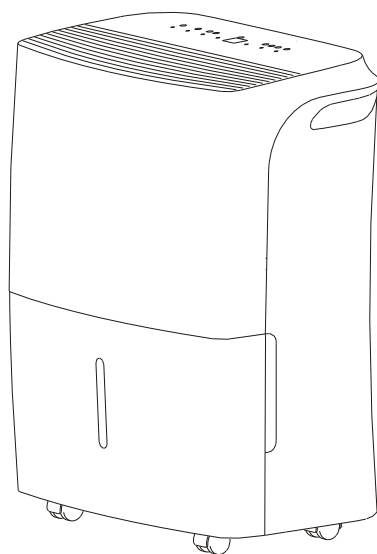

MODEL : ZD1919

Before operating this product, please read the instructions carefully and save this manual for future use.
ZANUSSI is a registered Trademark used under license from AB Electrolux (publ)

CONTENTS

SAFETY PRECAUTIONS

Warning	2
Caution	2
Electrical information	3

CONTROL PADS ON THE DEHUMIDIFIER

Control pads.....	4
Other features.....	5

IDENTIFICATION OF PARTS

Identification of parts	7
Positioning the unit	8

OPERATING THE UNIT

When using the unit	8
Removing the collected water	9

CARE AND MAINTENANCE

Care and cleaning of the dehumidifier	11
---	----

TROUBLESHOOTING TIPS

Troubleshooting tips	13
----------------------------	----

Read This Manual

Inside you will find many helpful hints on how to use and maintain your dehumidifier properly. Just a little preventive care on your part can save you a great deal of time and money over the life of your air conditioner. You'll find many answers to common problems in the chart of troubleshooting tips. If you review our chart of Troubleshooting Tips first, you may not need to call for service at all.





CAUTION

- This appliance can be used by children aged from 8 years and above and persons with reduced physical, sensory or mental capabilities or lack of experience and knowledge if they have been given supervision or instruction concerning use of the appliance in a safe way and understand the hazards involved. Children shall not play with the appliance. Cleaning and user maintenance shall not be made by children without supervision. (EN Standard requirements)
- This appliance is not intended for use by persons (including children) with reduced physical ,sensory or mental capabilities or lack of experience and knowledge, unless they have been given supervision or instruction concerning use of the appliance by a person responsible for their safety. Children should be supervised to ensure that they do not play with the appliance. (IEC Standard requirements)
- If the supply cord is damaged, it must be replaced by the manufacturer, its service agent or similarly qualified persons in order to avoid a hazard.
- The appliance shall be installed in accordance with national wiring regulations.
- The appliance with electric heater shall have at least 1 meter space to the combustible materials.
- Contact the authorised service technician for repair or maintenance of this unit.



SAFETY PRECAUTIONS

To prevent injury to the user or other people and property damage, the following instructions must be followed. Incorrect operation due to ignoring of instructions may cause harm or damage.

- The seriousness is classified by the following indications.

 WARNING	This symbol indicates the possibility of death or serious injury.
 CAUTION	This symbol indicates the possibility of injury or damage to property.

- Meanings of symbols used in this manual are as shown below.

	Never do this.
	Always do this.

WARNING

⊘ Do not exceed the rating of the power outlet or connection device.

- Otherwise, it may cause electric shock or fire due to excess heat generation.

⊘ Do not operate or stop the unit by switching on or off the power supply.

- It may cause electric shock or fire due to heat generation.

⊘ Do not damage or use an unspecified power cord.

- It may cause electric shock or fire.

⊘ Do not modify power cord length or share the outlet with other appliances

- It may cause electric shock or fire due to heat generation.

⊘ Do not insert or pull out plug with wet hands.

- It may cause electric shock.

⊘ Do not place the unit near a heat source.

- Plastic parts may melt and cause a fire.

⊘ Disconnect the power if strange sounds, smell, or smoke comes from it.

- It may cause fire and electric shock.

⊘ You should never try to take apart or repair the unit by yourself.

- It may cause failure of machine or electric shock.

⊘ Before cleaning, turn off the power and unplug the unit.

- It may cause electrical shock or injury.

⊘ Do not use the machine near flammable gas or combustibles, such as gasoline, benzene, thinner, etc.

- It may cause an explosion or fire.

⊘ Do not drink or use the water drained from the unit.

- It contains contaminants and could make you sick.

⊘ Do not take the water bucket out during operation.

- It may cause bucket full protect of the unit and cause electric shock.

CAUTION

⊘ Do not use the unit in small spaces.

- Lack of ventilation can cause overheating and fire.

⊘ Do not put in places where water may splash onto the unit.

- Water may enter the unit and degrade the insulation. It may cause an electric shock or fire.

⊘ Place the unit on a level, sturdy section of the floor.

- If the unit falls over, it may cause water to spill and damage belongings, or cause electrical shock or fire.

SAFETY PRECAUTIONS

CAUTION

⊘ Do not cover the intake or exhaust openings with cloths or towels.

- A lack of air flow can lead to overheating and fire.

⊘ Care should be taken when using the unit in a room with the following persons:

- Infants, children, elderly people, and people not sensitive to humidity.

⊘ Do not use in areas where chemicals are handled.

- This will cause the unit deterioration due to chemicals and solvents dissolved in the air.

⊘ Never insert your finger or other foreign objects into grills or openings. Take special care to warn children of these dangers.

- It may cause electric shock or failure of appliance.

⊘ Do not place heavy object on the power cord and take care so that the cord is not compressed.

- There is danger of fire or electric shock.

⊘ Do not climb up on or sit on the unit.

- You may be injured if you fall or if the unit falls over.

⊘ Always insert the filters securely. Clean filter once every two weeks.

- Operation without filters may cause failure.

⊘ If water enters the unit, turn the unit off and disconnect the power, contact a qualified service technician.

- It may cause failure of appliance or accident.

⊘ Do not place flower vases or other water container on top of the unit.

- Water may spill inside the unit, causing insulation failure and electrical shock or fire.

Electrical Information

- The manufactures nameplate is located on the rear panel of the unit and contains electrical and other technical data specific to this unit.
- Be sure the unit is properly grounded. To minimize shock and fire hazards, proper grounding is important. The power cord is equipped with a three-prong grounding plug for protection against shock hazards.
- Your unit must be used in a properly grounded wall receptacle. If the wall receptacle you intend to use is not adequately grounded or protected by a time delay fuse or circuit breaker (please refer to the nameplate for the electrical data), have a qualified electrician install the proper receptacle.
- Ensure the receptacle is accessible after the unit installation.
- **Do not use extension cords or an adapter plugs with this unit.**
- To avoid the possibility of personal injury, always disconnect the power supply to the unit, before installing and/or servicing.

CONTROL PADS ON THE DEHUMIDIFIER

NOTE: The control panel of the unit you purchased may be slightly different according to the models.

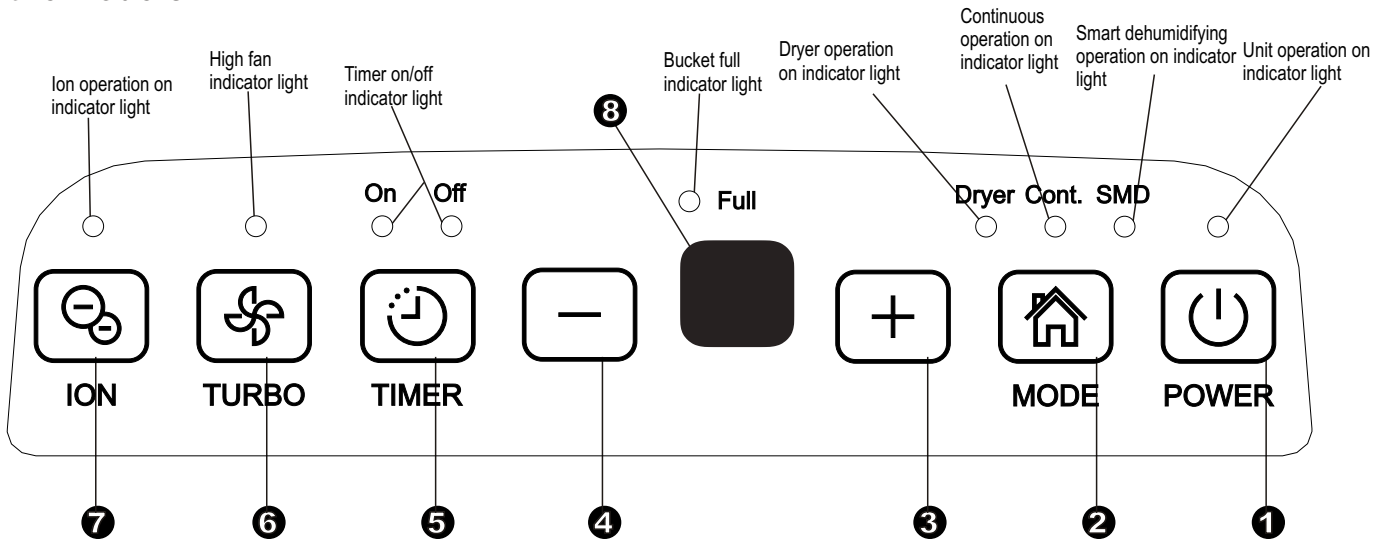

Control pads

When you push the button to change operation modes, the unit will make a beep sound to indicate that it is changing modes.

① Power Pad

Press to turn the dehumidifier on and off.
NOTE: When the compressor startups or stops running, the unit may make a loud voice, it is normal.

② Mode Pad

Press to select the desired operation mode from Dehumidifying, Dryer, Continuous dehumidifying and Smart dehumidifying.
NOTE: Dryer and Smart dehumidifying modes are optional.

③ ④ ⊕/⊖ : Down/Up Pads

• Humidity Set Control Pads

The humidity level can be set within a range of 35%RH(Relative Humidity) to 85%RH(Relative Humidity) in 5% increments.
For drier air, press the ⊖ pad and set to a lower percent value(%).
For damper air, press the ⊕ pad and set a higher percent value(%).

• TIMER Set Control Pads

Use the Up/Down pads to set the Auto start and Auto stop time from 0.0 to 24.

⑤ Timer Pad

Press to initiate the Auto start and Auto stop feature, in conjunction with the ⊕ and ⊖ key pads.

⑥ Turbo Pad

Control the fan speed. Press to select either High or Normal fan speed. Set the fan control to High for maximum moisture removal. When the humidity has been reduced and quiet operation is preferred, set the fan control to Normal.

⑦ Ion Pad(optional)

Press to activate the ionizer. Anions are automatically generated by ionization. The anions deactivate the airborne chemical vapors and dust particles. Press it again to stop the function.

CONTROL PADS ON THE DEHUMIDIFIER

⑧ Display

Shows the set % humidity level from 35% to 85% or auto start/stop time (0~24) while setting, then shows the actual ($\pm 5\%$ accuracy) room % humidity level in a range of 30%RH(Relative Humidity) to 90%RH (Relative Humidity).

Error Codes and Protection Codes:

AS- Humidity sensor error--Unplug the unit and plug it back in. If error repeats, call for service.

ES- Temperature sensor error-- Unplug the unit and plug it back in. If error repeats, call for service.

P1- Unit is defrosting-- Allow the unit time to automatically defrost. The protection will clear after the unit self defrosts.

P2- Bucket is full or bucket is not in right position-- Empty the bucket and replace it in the right position.

E3- Unit malfunction-- Unplug the unit and plug it back in. If error repeats, call for service.

EC- Refrigerant leakage detection malfunction-- Call for service.

Other features

Bucket Full Light

Glow when the bucket is ready to be emptied, or when the bucket is removed or not replaced in the proper position.

Auto Shut Off

The dehumidifier shuts off when the bucket is full, or when the bucket is removed or not replaced in the proper position. When the setting humidity is reached, the unit will be shut off automatically. For some models, the fan motor will continue to run for 30 seconds.

Auto Defrost

When frost builds up on the evaporator coils, the compressor will cycle off and the fan will continue to run until the frost disappears.

NOTE: When Auto defrosting operation, the unit may make a voice of refrigerant flowing, it is normal.

Wait 3 minutes before resuming operation

After the unit has stopped, it can not be restart operation in the first 3 minutes. This is to protect the unit. Operation will automatically start after 3 minutes.

Smart dehumidifying mode(optional)

At smart dehumidifying mode, the unit will automatically control room humidity in a comfortable range 45%~55% according to the room temperature. The humidity setting function will be invalid.

Auto-Restart

If the unit breaks off unexpectedly due to the power cut, it will restart with the previous function setting automatically when the power resumes.

Setting the Timer

- When the unit is on, first press the Timer button, the Timer Off indicator light illuminates. It indicates the Auto Stop program is initiated. Press it again the Time On indicator light illuminates. It indicates the Auto Start is initiated.
- When the unit is off, first press the Timer button, the TIMER ON indicator light illuminates. It indicates the Auto Start program is initiated. Press it again the Time Off indicator light illuminates. It indicates the Auto Stop is initiated.
- Press or hold the UP or DOWN pad to change the Auto time by 0.5 hour increments, up to 10 hours, then at 1 hour increments up to 24 hours. The control will count down the time remaining until start.
- The selected time will register in 5 seconds and the system will automatically revert back to display the previous humidity setting.
- When the Auto start & Auto stop times are set, within the same program sequence,
- TIMER ON OFF indicator lights illuminate identifying both ON and OFF times are now programmed.
- Turning the unit ON or OFF at any time or adjusting the timer setting to 0.0 will cancel the Auto Start/Stop function.
- When LED display window displays the code of P2, the Auto Start/Stop function will also be cancelled.

CONTROL PADS ON THE DEHUMIDIFIER

Dryer mode(optional)

The unit can make the MAX dehumidification function when it is under the Dryer mode. The fan speed is fixed at high fan speed. The humidity level is automatically controlled according to the actual room humidity. The unit will quit dryer mode after a maximum 10 hours' operation.

NOTE:

- The Dryer mode must be operated in a close room, do not open the door and window.
- To make the best effective dehumidification, please first dehydrate the wet clothes.
- Make sure to direct airflow at the wet clothes (See Fig.A).
- For thick and heavy wet clothes may not get the best effective dehumidification.

⚠ CAUTION

- Do not cover the air outlet of the unit with clothes. It may cause excessive heat, fire or failure of unit.
- Do not place the wet clothes on the top of the unit and do not make the water drop into the unit. It may cause electric shock, creepage or failure of unit.

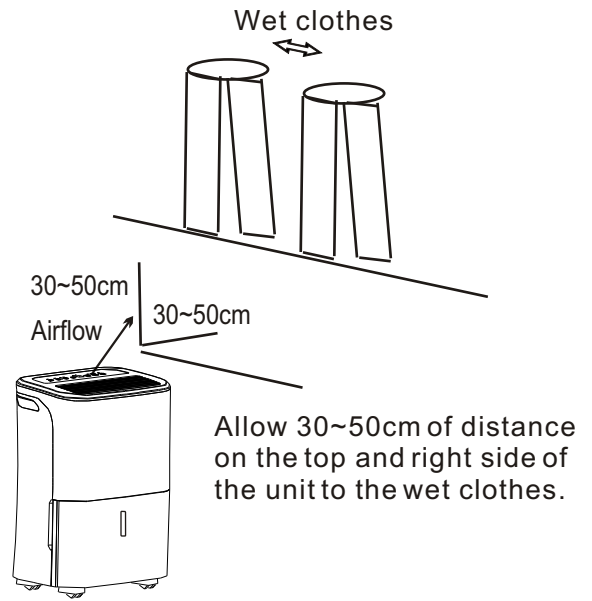

Fig.A

IDENTIFICATION OF PARTS

Identification of parts

Front

- ❶ Control panel
- ❷ Handle (both sides)
- ❸ Air outlet grille
- ❹ Water bucket
- ❺ Water level window

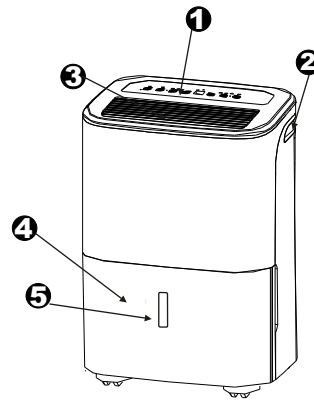

Rear

- ❶ Drain hose outlet
- ❷ Caster
- ❸ Power Cord and plug
- ❹ Air intake grille
- ❺ Air filter (behind the grill)
- ❻ Power cord Buckle(Used only when storing the unit.)

Fig.2

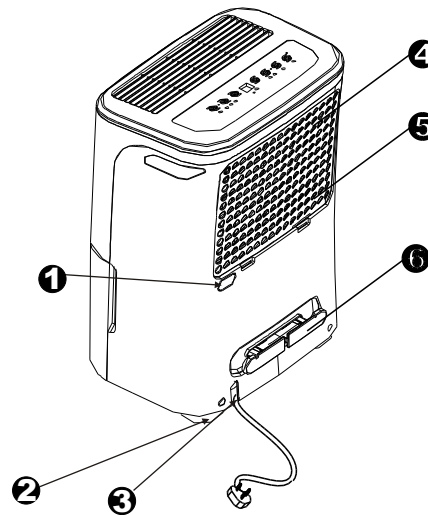

Fig.3

NOTE: All the pictures in the manual are for explanation purposes only. The actual shape of the unit you purchased may be slightly different, but the operations and functions are the same.

OPERATING THE UNIT

Positioning the unit

A dehumidifier operating in a basement will have little or no effect in drying an adjacent enclosed storage area, such as a closet, unless there is adequate circulation of air in and out of the area.

- Do not use outdoors.
- This dehumidifier is intended for indoor residential applications only. This dehumidifier should not be used for commercial or industrial applications.
- Place the dehumidifier on a smooth, level floor strong enough to support the unit with a full bucket of water.
- Allow at least 20cm of air space on all sides of the unit for good air circulation.
- Place the unit in an area where the temperature will not fall below 5°C(41°F). The coils can become covered with frost at temperatures below 5°C(41°F), which may reduce performance.
- Place the unit away from the clothes dryer, heater or radiator.
- Use the unit to prevent moisture damage anywhere books or valuables are stored.
- Use the dehumidifier in a basement to help prevent moisture damage.
- The dehumidifier must be operated in an enclosed area to be most effective.
- Close all doors, windows and other outside openings to the room.

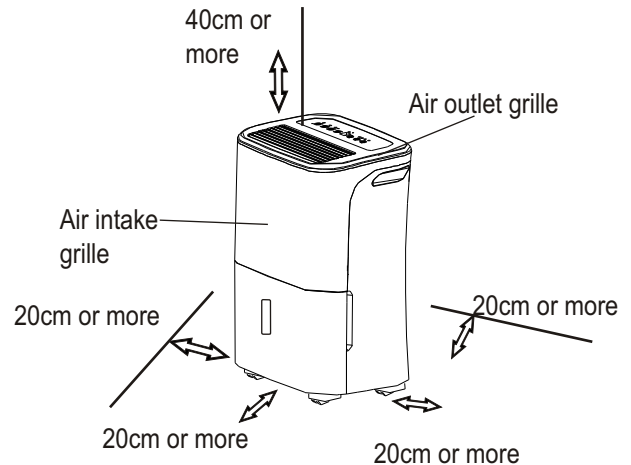

Casters(Install at four points on the bottom of unit)

- Do not force casters to move over carpet, nor move the unit with water in the bucket. (The unit may tip over and spill water.)

NOTE:Casters is optional,some models without.

When using the unit

- When first using the dehumidifier, operate the unit continuously 24 hours.
- This unit is designed to operate with a working environment between 5°C/41°F and 35°C/95°F.
- If the unit has been switched off and needs to be switched on again quickly, allow approximately three minutes for the correct operation to resume.
- Do not connect the dehumidifier to a multiple socket outlet, which is also being used for other electrical appliances.
- Select a suitable location, making sure you have easy access to an electrical outlet.
- Plug the unit into a electrical socket-outlet with earth connection.
- Make sure the Water bucket is correctly fitted otherwise the unit will not operate properly.

NOTE:When the water in the bucket reaches to a certain level,please be careful to move the machine to avoid it falling down.

Removing the collected water

There are two ways to remove collected water.

1. Use the bucket

- When the unit is off, if the bucket is full, the unit will beep 8 times and the Full indicator light will flash, the digital display shows P2.
- When the unit is on, if the bucket is full, the compressor turns off and the fan turns off after 30 seconds for drying the water of the condenser, then the unit will beep 8 times and the Full indicator light will flash, the digital display shows P2.
- Slowly pull out the bucket. Grip the left and right handles securely, and carefully pull out straight so water does not spill. Do not put the tank on the floor because the bottom of the bucket is uneven. Otherwise the bucket will fall and cause the water to spill.
- Throw away the water and replace the bucket. The bucket must be in place and securely seated for the dehumidifier to operate.
- The machine will re-start when the bucket is restored in its correct position.

NOTES:

- When you remove the bucket, do not touch any parts inside of the unit. Doing so may damage the product. Be sure to push the bucket gently all the way into the unit.
- Banging the bucket against anything or failing to push it in securely may cause the unit not to operate.
- When you remove the bucket, if there is some water in the unit you must dry it .

1. Pull out the bucket a little.

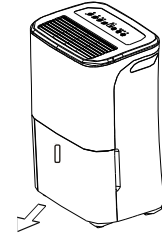

Fig.5

2. Hold both sides of the bucket with even strength, and pull it out from the unit.

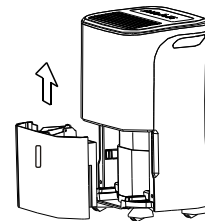

Fig.6

3. Pour the water out.

OPERATING THE UNIT

Removing the collected water

2. Continuous draining

Water can be automatically emptied into a floor drain by attaching the unit with a water hose(not included).

Cut the cover down from the back drain hose outlet. Attach a drain hose(ID=13.5mm) and lead it to the floor drain or a suitable drainage facility(see Fig.7).

Make sure the hose is secure so there are no leaks.

Direct the hose toward the drain,making sure that there are no kinks that will stop the water flowing.

Place the end of the hose into the drain and make sure the end of the hose is level or down to let the water flow smoothly.Do never let it up.

Make sure the water hose is lower than the drain hose outlet.

Select the desired humidity setting and fan speed on the unit for continuous draining to start.

NOTE: When the continuous drain feature is not being used, remove the drain hose from the outlet.

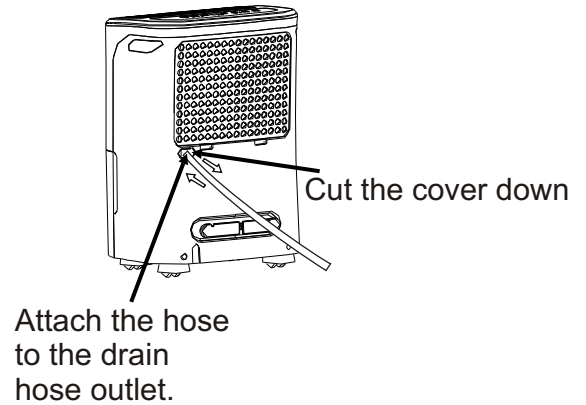

Fig.7

Care and cleaning of the dehumidifier

Turn the dehumidifier off and remove the plug from the wall outlet before cleaning.

1. Clean the Grille and Case

- Use water and a mild detergent. Do not use bleach or abrasives.
- Do not splash water directly onto the main unit. Doing so may cause an electrical shock, cause the insulation to deteriorate, or cause the unit to rust.
- The air intake and outlet grilles get soiled easily, so use a vacuum attachment or brush to clean.

2. Clean the bucket

Every few weeks, clean the bucket to prevent growth of mold, mildew and bacteria. Partially fill the bucket with clean water and add a little mild detergent. Swish it around in the bucket, empty and rinse.

NOTE: Do not use a dishwasher to clean the bucket. After clean, the bucket must be in place and securely seated for the dehumidifier to operate.

3. Clean the air filter

The air filter behind the front grille should be checked and cleaned at least every 30 days or more often if necessary.

NOTE: DO NOT RINSE OR PUT THE FILTER IN AN AUTOMATIC DISHWASHER.

To remove:

- Grip the tab on the filter and pull it upward, then pull it out as shown in Fig.8.
- Clean the filter with warm, soapy water. Rinse and let the filter dry before replacing it. Do not clean the filter in a dishwasher.

To attach:

- Insert the air filter into the unit from underside to upside. See Fig.10.

CAUTION:

DO NOT operate the dehumidifier without a filter because dirt and lint will clog it and reduce performance.

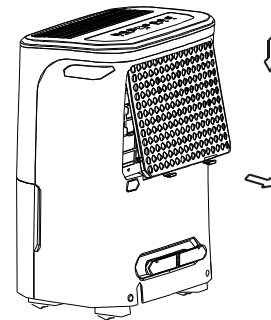

Fig. 8

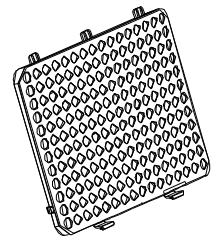

Fig. 9

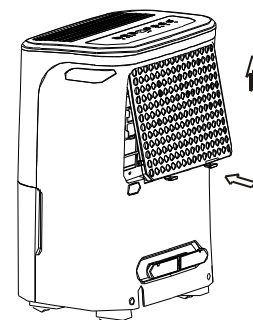

Fig. 10

CARE AND MAINTENANCE

Care and cleaning of the dehumidifier

4. When not using the unit for long time periods

- After turning off the unit, wait one day before emptying the bucket.
- Clean the main unit, water bucket and air filter.
- Cover the unit with a plastic bag.
- Store the unit upright in a dry, well-ventilated place.

TROUBLESHOOTING TIPS

Before calling for service, review the chart below first yourself.

Problem	What to check
Unit does not start	<ul style="list-style-type: none">● Make sure the dehumidifier's plug is pushed completely into the outlet.● Check the house fuse/circuit breaker box.● Dehumidifier has reached its preset level or bucket is full.● Water bucket is not in the proper position.
Dehumidifier does not dry the air as it should	<ul style="list-style-type: none">● Did not allow enough time to remove the moisture.● Make sure there are no curtains, blinds or furniture blocking the front or back of the dehumidifier.● The humidity control may not be set low enough.● Check that all doors, windows and other openings are securely closed.● Room temperature is too low, below 5°C(41°F).● There is a kerosene heater or something giving off water vapor in the room.
The unit makes a loud noise when operating	<ul style="list-style-type: none">● The air filter is clogged.● The unit is tilted instead of upright as it should be.● The floor surface is not level.
Frost appears on the coils	<ul style="list-style-type: none">● This is normal. The dehumidifier has Auto defrost feature.
Water on floor	<ul style="list-style-type: none">● Hose to connector or hose connection may be loose.● Intend to use the bucket to collect water, but the back drain plug is removed.
ES, AS, E3, EC,P1 or P2 appear in the display	<ul style="list-style-type: none">● These are error codes and protection codes. See the CONTROL PADS ON THE DEHUMIDIFIER section.

Specifications

Model No.:	ZD1919
Dehumidify capacity:	9L/DAY (26.7°C RH=60%) 20L/DAY (32°C RH=90%)
Rated Voltage:	220V~
Rated Frequency:	50Hz
Input power:	234W (26.7°C RH=60%) 280W (30°C RH=80%)
Tank Capacity:	3L
Air Volume:	150m ³ /h
Refrigerant:	R134a/95g
Noise Level _(sound Pressure) :	47dB(A)
Net weight:	15.1kg
Suction Pressure:	1.7MPa
Discharge pressure:	0.7MPa

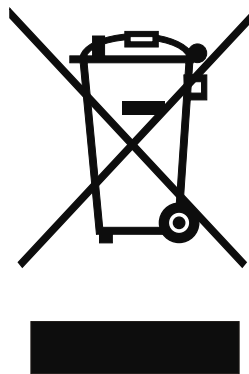

Note About Fluorinated Gasses

- Fluorinated greenhouse gases are contained in hermetically sealed equipment. For specific information on the type, the amount and the CO₂ equivalent in tonnes of the fluorinated greenhouse gas (on some models), please refer to the relevant label on the unit itself.
- Installation, service, maintenance and repair of this unit must be performed by a certified technician.
- Product uninstallation and recycling must be performed by a certified technician.

The design and specifications are subject to change without prior notice for product improvement. Consult with the sales agency or manufacturer for details. Any updates to the manual will be uploaded to the service website, please check for the latest version.

CD031IU-DF(ZG)
16120100000251